

Recommended Spare Parts Lists

Model	Page Code		Applicable Manufacturing Number
	Spare Parts List	Location of Spare Parts	
RPI- 8,0FSN2E 1~ 230V 50Hz	EPN-0811A-1A	EPN-0811A-1B	From the First Production
RPI-10.0FSN2E 1~ 230V 50Hz			

No.	DESCRIPTION	DWG No.	PART No.	MODEL NAME		REMARKS
				RPI-8.0FSN2E 1~230V 50Hz	RPI-10.0FSN2E 1~230V 50Hz	
				PRODUCT CODE		
				7E420010		
				7E420011		
No.	DESCRIPTION	DWG No.	PART No.	Qty	Qty	REMARKS
U00	Terminal Board	XEK21159 A	E00750	1	1	
U02	Remote Control SW	7E899954	E01516	1	1	PC-P2HTE (Optional)
U02	Remote Control SW	70510000	E01693	1	1	PC-ART (Optional)
U04	Fuse	XEK32373 B	E00809	1	1	10A
U13	Electrical Box	XEK00991 A	E01841	1	1	Assembly (Components + Harness)
U14	Capacitor	XEK20633 M	E01021	1		18µF
U14	Capacitor	XEK20633 Q	E01842		1	25µF
U15A	Thermistor	17C74419 J	E01198	1	1	For liquid Pipe
U15B	Thermistor	17C74419 F	E01843	1	1	For Gas Pipe
U15C	Thermistor	XEK11209 F	E01238	1	1	For Inlet Air
U15D	Thermistor	XEK11209 H	E01239	1	1	For Outlet Air
U20	Fuse Holder	17C66740 A	E01015	1	1	
U21	Expansion Valve	17C87882 B	E00856	2		
U21	Expansion Valve	17C87883 B	E01716		2	
U31	Filter	XEK35381 A	E01844	1	1	
U37A	Fan Casing/Runner R	XEK23103 A	E01845	1	1	Fan Casing + Runner (Right)
U37B	Fan Casing/Runner L	XEK23104 A	E01846	1	1	Fan Casing + Runner (Left)
U41	Heat Exchanger	XEK11651 A	E01847	1		Assembly
U41	Heat Exchanger	XEK11652 A	E01848		1	Assembly
U65A	Spacer	XEK30992 B	P19112	8	8	For PCB Fixing
U71A	Fan Assy	XEK11663 A	E01849	1	1	(Stay + Base + Motor + Cassings + Runners)
U71B	Fan Motor	XEK11664 A	E01850	1	1	
U75	Power Relay	17B05678 C	C3950	1	1	
U82	Transformer	17B26061 A	E01242	1	1	
U85A	Printed Circuit Board	17B37988 E	E01851	1	1	(PI065 ASSY)
U85B	Relay PCB	17C67473 A	E01037	1	1	
U87	Float Switch	17B24618 A	E01038	1	1	

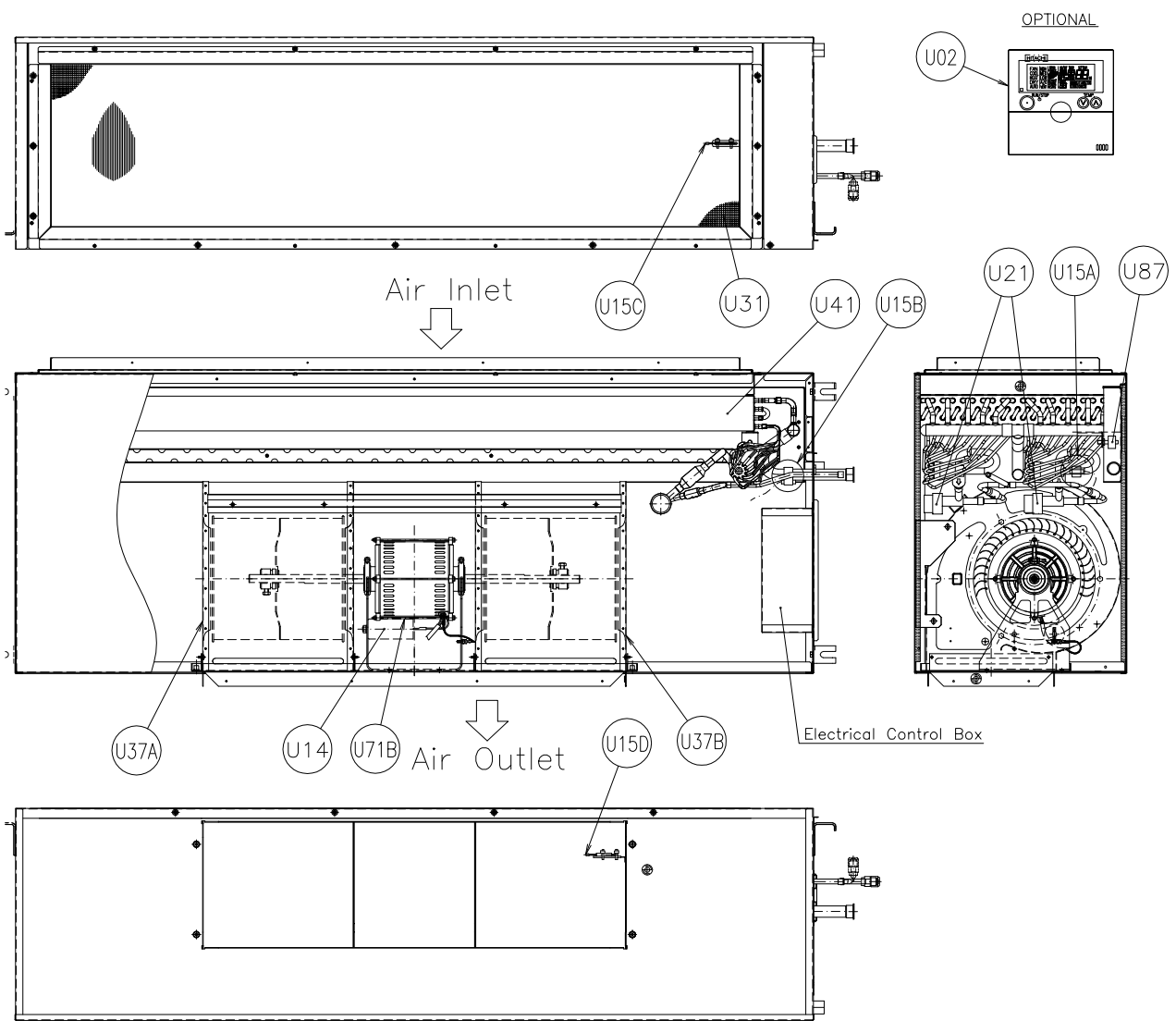

LOCATION OF ELECTRICAL EQUIPMENT IN THE ELECTRICAL BO

