

Location of Spare Parts in The Air Panel (Optional)

MODEL: RCD-1.0FSN2
 RCD-1.5FSN2
 RCD-2.0FSN2
 RCD-2.5FSN2
 RCD-3.0FSN2
 and
 P-N23DNA
 P-N23DWA

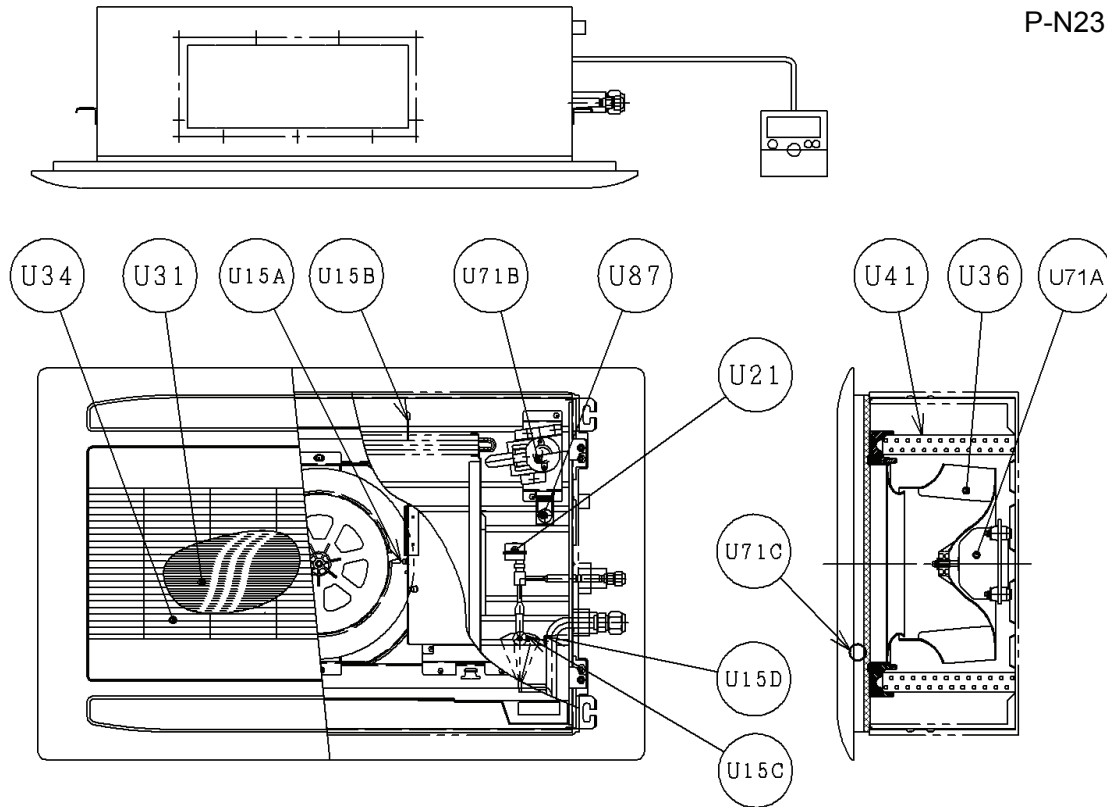

Location of Electrical Equipment in The Electrical Box

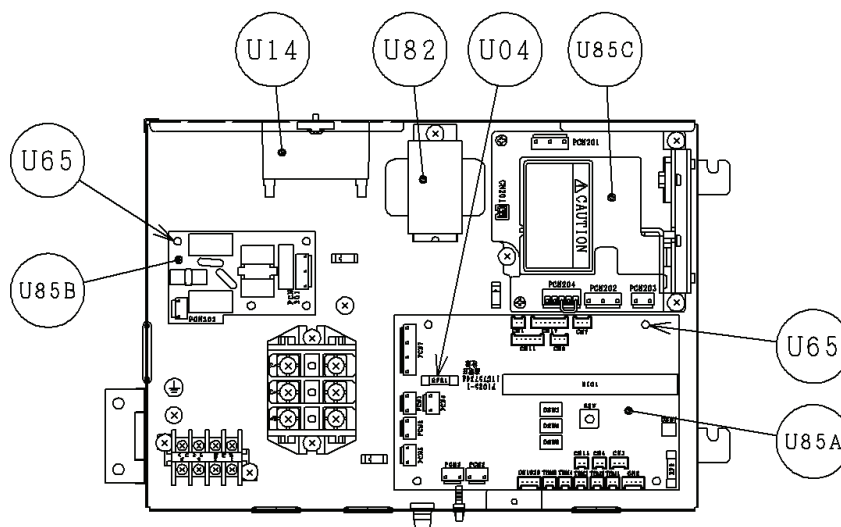

D-RCD-1.0FSN2-Z, D-RCD-1.5FSN2-Z, D-RCD-2.0FSN2-Z, D-RCD-2.5FSN2-Z, D-RCD-3.0FSN2-Z