

PRODUCT CODE  
 7E351005  
 MODEL NAME  
 RASM-3VNE, 1~ 230V 50Hz

No.	DESCRIPTION	DWG No.	PART No.	Qty	REMARKS
1	Rear Cover S Assy	XEK23801 A	E02717	1	
1-1	Handle	X17C71740 A	E01897	3	
1-2	H Cover	17B27407 A	P23833	1	
1-3	Pipe Cover 2 B	XEK23802 A	E02719	1	
1-4	Pipe Cover B	17C86251 A	P27003	1	
1-5	Rear Cover S	XEK01115 A	E04890	1	
2	Upper Cover Assy	XEK23441 A	E02148	1	
3	Service Cover S Assy	XEK25450 A	E04891	1	
4	S Cover B	17B40022 A	E02149	1	Lower Service Cover
5	Protector Net S Assy	XEK24693 A	E01785	1	
6	Shroud S Assy	XEK22983 A	E02393	1	
6-1	Shroud S	XEK00948 A	E01795	1	
6-2	Front Protector Net	17A17019 A	E02876	1	Air Outlet
7	Clamp S Assy	XEK24429 A	E03338	1	Assembly
8	Fan Motor	17B41808 A	P28608	1	MOF, DC100W, 8P
9	Propeller Fan	17A17362 B	P27001	1	Ø 544
10	B-Base Assy	XEK25246 A	E04892	1	Assembly
11	Compressor	17B42994 C	P29028	1	DC Comp. 2YC45KXD
12	THM Support D	17G85310 A	E01819	1	
13	C Heater	17C75113 P	P29159	2	240V-30W
14	Special Nut	17G64891 A	P27595	1	
15	Acoustical Cover	17F05829 B	P28610	1	
16	Acoustical Cover 1	17F05830 A	P28915	1	Upper Cover
17	Condenser	XEK12131 A	E03339	1	Assembly (Heat exchanger + 14-1+17-2)
17-1	Header L Unit	XEK24464 A	E03341	1	Assembly
17-1-1	EVO Assy	XEK37473 A	E03413	1	Assembly
17-1-1-1	Expansion Valve	17F05654 A	P28614	1	EVO
17-1-1-2	Strainer	17G62701 B	P25037	2	
17-2	Header G Unit	17F05094 A	E03340	1	Assembly
18	EXPV Coil	17C78180 D	P28615	1	Coil for Expansion Valve
19	Stay	17G57303 A	E02105	1	
20	End P Unit	17C87812 A	E02401	1	
21	Partition S Assy	XEK22987 A	E02402	1	
22	Accumulator	XEK24960 A	E01800	1	

MODEL NAME  
 RASM-3VNE, 1 ~ 230V 50Hz  
 PRODUCT CODE  
 7E351005

No.	DESCRIPTION	DWG No.	PART No.	Qty	REMARKS
23	Strainer	17H07319 B	P28618	1	
24	Pressure SW	XEK24355 A	E03342	1	For Low Pressure
25	Coil 20	17C64850 B	P25454	1	Coil for Solenoid Valve
26	Coil	17F07261 A	P29857	1	Coil for 4-Way Valve
27	4-Way Valve Assy	XEK12134 A	E03343	1	Assembly
27-1	D Pipe Unit	XEK37450 A	E03424	1	Assembly
27-1-1	Silencer	17H05922 B	P28630	1	
27-1-2	Pressure SW	XEK22551 A	P25043	1	PSH (High)
27-1-3	P-Sensor	X17B46257 A	E04508	1	PSC (Control)
27-2	SVC Assy	17H07318 A	E03344	1	
27-2-1	Solenoid Valve	17C77098 A	P25246	1	SVA
27-3	4 Way Valve	17F06920 A	P30581	1	RVR
27-4	Stop Valve	XEK25610 A	E04702	1	For liquid line 3/8
27-5	Stop Valve	XEK25609 A	E01512	1	For gas line 5/8
27-6	Valve Stay	17G82214 A	E02111	1	
27-7	Check JA	17C75461 B	P25044	1	
28	V-Stay	17G40832 B	E03345	1	
29	Thermistor	17C59663 E	P23505	1	For Outdoor Temp., THM7
30	Thermistor	17C59664 D	P23504	1	For Outdoor Temp., THM8
31	Thermistor	17B24597 K	P23508	1	For Discharge Gas Temp., THM9
32	TH-Plate	XEK21470 A	E01901	1	
33	Air Purge	XEK38252 A	E04040	1	
34	Security valve	XEK37800 A	E02475	1	
35	Expansion vessel	XEK25338 A	E04893	1	
36	Pump	XEK25342 A	E04894	1	
37	PHEX unit	XEK25478 A	E04895	1	Assembly (from 37-1 to 37-7)
37-1	Plate HEX	XEK25315 C	E04896	1	
37-2	Expansion valve	X17F04392 A	E03077	1	
37-3	Strainer	17G62700 A	P25041	2	
37-4	Liquid tank	XEK25069 A	E04901	1	
37-5	Flare Nut	25JR0900	E02489	1	Liquid connection
37-6	Flare Nut	25JR1700	E02490	1	Gas connection
37-7	Water heater	XEK39021 A	E04609	1	
38	Filter ball	XEK25346 A	E04897	1	

					PRODUCT CODE
					7E351005
					MODEL NAME
					RASM-3VNE, 1~ 230V 50HZ
No.	DESCRIPTION	DWG No.	PART No.	Qty	REMARKS
38-1	Mesh	XEK39398 A	E04898	1	
38-1	Seeger	XEK39399 A	E04899	1	
39	Gasket	XEK36144 B	E03832	4	
40	Gasket	XEK36397 A	E02528	2	
41	Gasket	XEK36144 A	E02497	1	
42	Union	XEK36303 A	E02507	1	
43	Drain pipe	XEK36103 A	E02546	1	Vynil tube d.16mm x 1m
44	Thermistor Assy 1	XEK25398 A	E04903	1	THM WI (Water in)
45	Thermistor Assy 1	XEK25398 D	E04904	1	THM WO (Water out)
46	Thermistor Assy 2	XEK25399 G	E04905	1	THM G (Gas)
47	Thermistor Assy 2	XEK25399 H	E04906	1	THM L (Liquid)
48	P-spring	17G27651 B	E02549	1	For Liquid THM fixing
49	P-spring	17G27651 C	E02550	1	For Gas THM fixing
50	P-spring	17G31457 D	E01193	2	For Water THM fixing
51	Gasket	XEK36144 D	E04873	1	

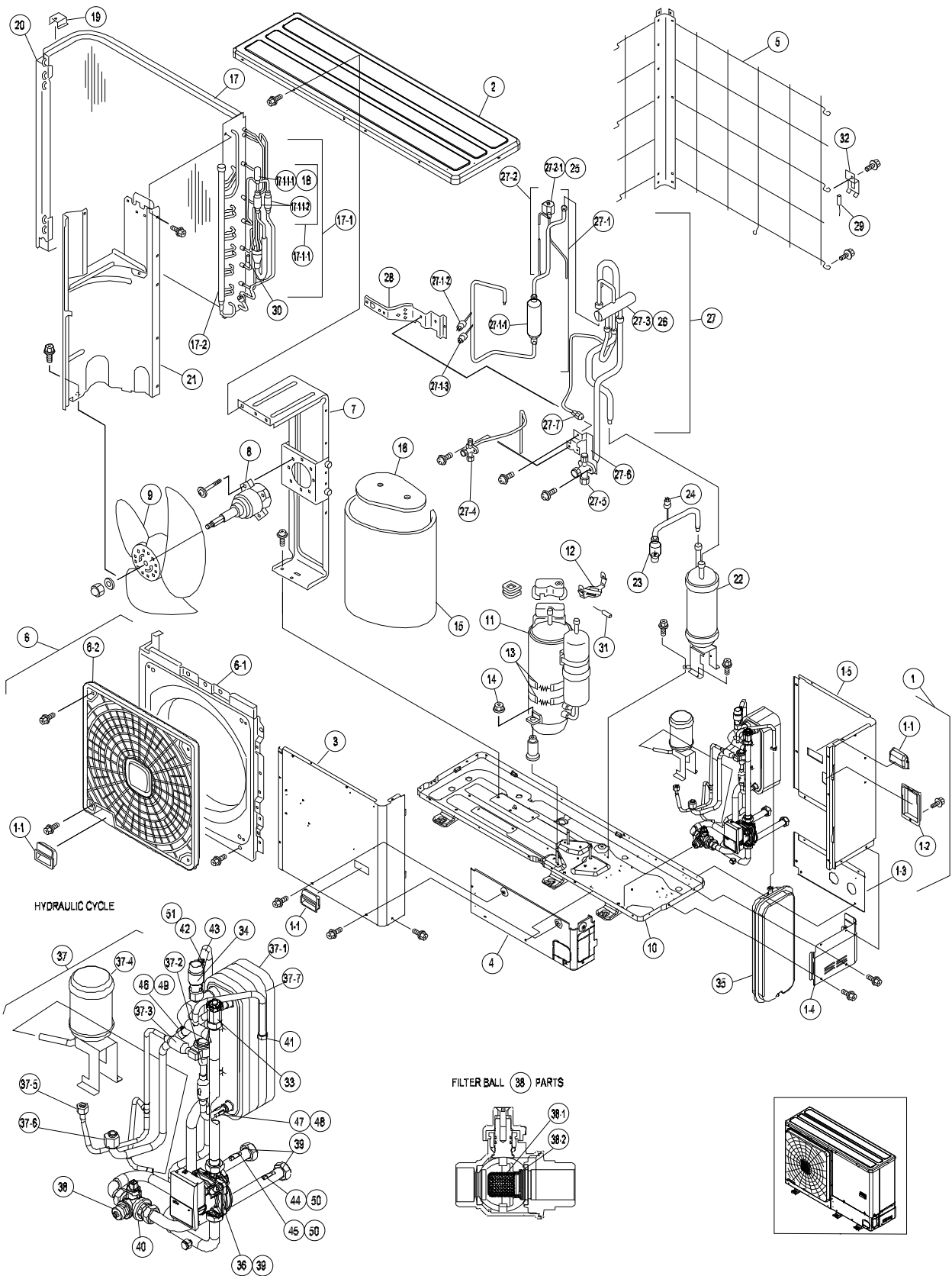

No.	DESCRIPTION	DWG No.	PART No.	MODEL NAME			REMARKS
				PRODUCT CODE	Qty	Qty	
				RASM-4NE, 3~ 230V 50Hz	7E351107		
				RASM-5NE, 3~ 230V 50Hz	7E351108		
				RASM-6NE, 3~ 230V 50Hz	7E351109		
1	Electrical Box	XEK01510 A	E04804	1			Assembly (2+3+Harness)
1	Electrical Box	XEK01510 B	E04805		1		Assembly (2+3+Harness)
1	Electrical Box	XEK01510 C	E04806			1	Assembly (2+3+Harness)
2	P Plate Unit	XEK12139 B	E04807	1	1	1	Assembly (2-1~2-11)
2-1	P Plate Assy	XEK37454 A	E03366	1	1	1	Assembly
2-2	PCB Additional Work	XEK39667 B	E04668	1	1	1	PCB1, PO101B Assy
2-3	Spacer	XEK30992 B	P19112	6	6	6	For PCB1
2-4	Push Spacer	XEK31888 A	E00738	2	2	2	For PCB1
2-5	Terminal Board	XEK20967 A	E00705	1	1	1	TB
2-6	Noise Filter	17B41798 A	P28595	1	1	1	NF
2-7	Spacer	XEK34315 A	E01789	6	6	6	For Noise Filter
2-8	Fuse Holder	X17C66740 A	E01015	2	2	2	
2-9	Fuse	XEK32373 D	E00810	2	2	2	20A
2-10	Reactor Unit	XEK36243 C	E03374	1	1	1	
2-11	MG SW	17B28277 B	P24721	1	1	1	Fuji Electric,FC-0/SP
3	Power Unit Assy	XEK24441 A	E03375	1	1	1	Assembly (3-1~3-2)
3-1	Power Stay Assy	XEK36266 A	E02437	1	1	1	Assembly
3-2	Inv. Fin Assy	17F04353 B	E03376	1	1	1	
4	Upper Support	XEK36287 A	E02427	1	1	1	
5	Support Ebox	XEK39553 A	E04962	1	1	1	

No.	DESCRIPTION	DWG No.	PART No.	PRODUCT CODE						REMARKS
				MODEL NAME						
				RASM-4VNE, 1~ 230V 50HZ	RASM-5VNE, 1~ 230V 50HZ	RASM-6VNE, 1~ 230V 50HZ	RASM-4NE, 3~ 230V 50HZ	RASM-5NE, 3~ 230V 50HZ	RASM-6NE, 3~ 230V 50HZ	
37	Air Purge	XEK38252 A	E04040	1	1	1	1	1		
38	Security valve	XEK37800 A	E02475	1	1	1	1	1		
39	Expansion vessel	XEK25338 A	E04893	1	1	1	1	1		
40	Pump	XEK25343 A	E04837	1	1	1	1	1		
41	PHEX unit	XEK25482 A	E04919	1			1			Assembly (from 41-1 to 41-6)
41	PHEX unit	XEK25482 B	E04920		1	1		1	1	Assembly (from 41-1 to 41-6)
41-1	Plate HEX	XEK25377 A	E04836	1			1			
41-1	Plate HEX	XEK25377 B	E04835		1	1		1	1	
41-2	Expansion valve	X17F04392 A	E03077	1			1			
41-2	Expansion valve	X17F04393 A	E03078		1	1		1	1	
41-3	Strainer	17G55723 A	P24399	2	2	2	2	2	2	
41-4	Flare Nut	25JR0900	E02489	1	1	1	1	1	1	Liquid connection
41-5	Flare Nut	25JR1700	E02490	1	1	1	1	1	1	Gas connection
41-6	Water heater	XEK39021 A	E04609	1	1	1	1	1	1	
42	Gasket	XEK36144 B	E03832	4	4	4	4	4	4	
43	Gasket	XEK36397 A	E02528	2	2	2	2	2	2	
44	Gasket	XEK36144 A	E02497	1	1	1	1	1	1	
45	Gasket	XEK36144 C	E04824	1	1	1	1	1	1	
46	Filter ball	XEK25346 A	E04897	1	1	1	1	1	1	
46-1	Mesh	XEK39398 A	E04898	1	1	1	1	1	1	
46-2	Seeger	XEK39399 A	E04899	1	1	1	1	1	1	
47	Union	XEK36303 A	E02507	1	1	1	1	1	1	
48	Drain pipe	XEK36103 A	E02546	1	1	1	1	1	1	Vynil tube d.16mm x 1m
49	Thermistor Assy 1	XEK25380 A	E04928	1	1	1	1	1	1	THM WI (Water in)
50	Thermistor Assy 1	XEK25380 D	E04929	1	1	1	1	1	1	THM WO (Water out)
51	Thermistor Assy 2	XEK25399 A	E04930	1	1	1	1	1	1	THM G (Gas)
52	Thermistor Assy 2	XEK25381 C	E04931	1	1	1	1	1	1	THM L (Liquid)
53	P-spring	17G27651 B	E02549	1	1	1	1	1	1	For Liquid THM fixing
54	P-spring	17G27651 C	E02550	1	1	1	1	1	1	For Gas THM fixing
55	P-spring	XEK36252 A	E02551	2	2	2	2	2	2	For Water THM fixing
56	Gasket	XEK36144 D	E04873	1	1	1	1	1	1	

No.	DESCRIPTION	DWG No.	PART No.	MODEL NAME						REMARKS		
				PRODUCT CODE	MODEL NAME	Qty	Qty	Qty	Qty		Qty	Qty
21	Condenser	XEK01260 A	E03353	RASM-4VNE, 1~ 230V 50Hz	7E351007	1	1	1	1	1	1	Assembly(Heat exchanger + 21-1+21-2)
21-1	Header L Unit	XEK24465 A	E03355	RASM-5VNE, 1~ 230V 50Hz	7E351008	1	1	1	1	1	1	Assembly
21-1-1	EVO Assy	XEK37471 A	E03414	RASM-6VNE, 1~ 230V 50Hz	7E351009	1	1	1	1	1	1	Assembly
21-1-1-1	Expansion Valve	17F05654 A	P28614	RASM-4NE, 3~ 230V 50Hz	7E351107	1	1	1	1	1	1	EVO
21-1-1-2	Strainer	17G62701 B	P25037	RASM-5NE, 3~ 230V 50Hz	7E351108	2	2	2	2	2	2	
21-2	Header G Unit	17F07363 A	E03354	RASM-6NE, 3~ 230V 50Hz	7E351109	1	1	1	1	1	1	Assembly
22	EXPV Coil	17C78180 A	P26009			1	1	1	1	1	1	Coil for Expansion Valve
23	Stay	17G57303 A	E02105			2	2	2	2	2	2	
24	End P Unit	17C87812 B	E02107			1	1	1	1	1	1	
25	Partition Assy	XEK22987 C	E01896			1	1	1	1	1	1	
26	Tank Assy	XEK25627 A	E04916			1	1	1	1	1	1	Assembly
27	Strainer	17G55723 A	P24399			1	1	1	1	1	1	
28	Pressure SW	XEK24355 A	E03342			1	1	1	1	1	1	For Low Pressure
29	Coil 20	17C64850 B	P25454			2	2	2	2	2	2	Coil for Solenoid Valve
30	Coil	17F07261 A	P29857			1	1	1	1	1	1	Coil for 4-Way Valve
31	4-Way Valve Assy	XEK12135 A	E03358			1	1	1	1	1	1	Assembly
31-1	D Pipe Unit	XEK37451 A	E03425			1	1	1	1	1	1	Assembly
31-1-1	Check Valve	17C84659 A	P10777			1	1	1	1	1	1	
31-1-2	Silencer	17H05922 A	P28629			1	1	1	1	1	1	
31-1-3	Pressure SW	XEK22551 A	P25043			1	1	1	1	1	1	PSH (High)
31-1-4	P-Sensor	X17B46257 A	E04508			1	1	1	1	1	1	PSC (Control)
31-2	SVC Assy	17H08917 A	E03361			1	1	1	1	1	1	
31-2-1	Solenoid Valve	17C77098 A	P25246			2	2	2	2	2	2	SVA
31-3	SVA Assy	17H12381 A	E03360			1	1	1	1	1	1	Assembly
31-4	4 Way Valve	17F06922 A	P29252			1	1	1	1	1	1	RVR
31-5	Check JA	17C75461 A	P25932			1	1	1	1	1	1	
31-6	Stop Valve	XEK25610 A	E04702			1	1	1	1	1	1	For liquid line 3/8
31-7	Stop Valve	17F06815 A	P28924			1	1	1	1	1	1	For gas line 5/8
31-8	Valve Stay	17F07248 A	E03362			1	1	1	1	1	1	
32	V-Stay	17F07129 A	E03363			1	1	1	1	1	1	
33	Thermistor	17C59663 E	P23505			1	1	1	1	1	1	For Outdoor Temp., THM7
34	Thermistor	17C59664 D	P23504			1	1	1	1	1	1	For Pipe Temp., THM8
35	Thermistor	17B24597 A	P22521			1	1	1	1	1	1	For Discharge Gas Temp. THM9
36	TH-Plate	XEK21470 A	E01901			1	1	1	1	1	1	

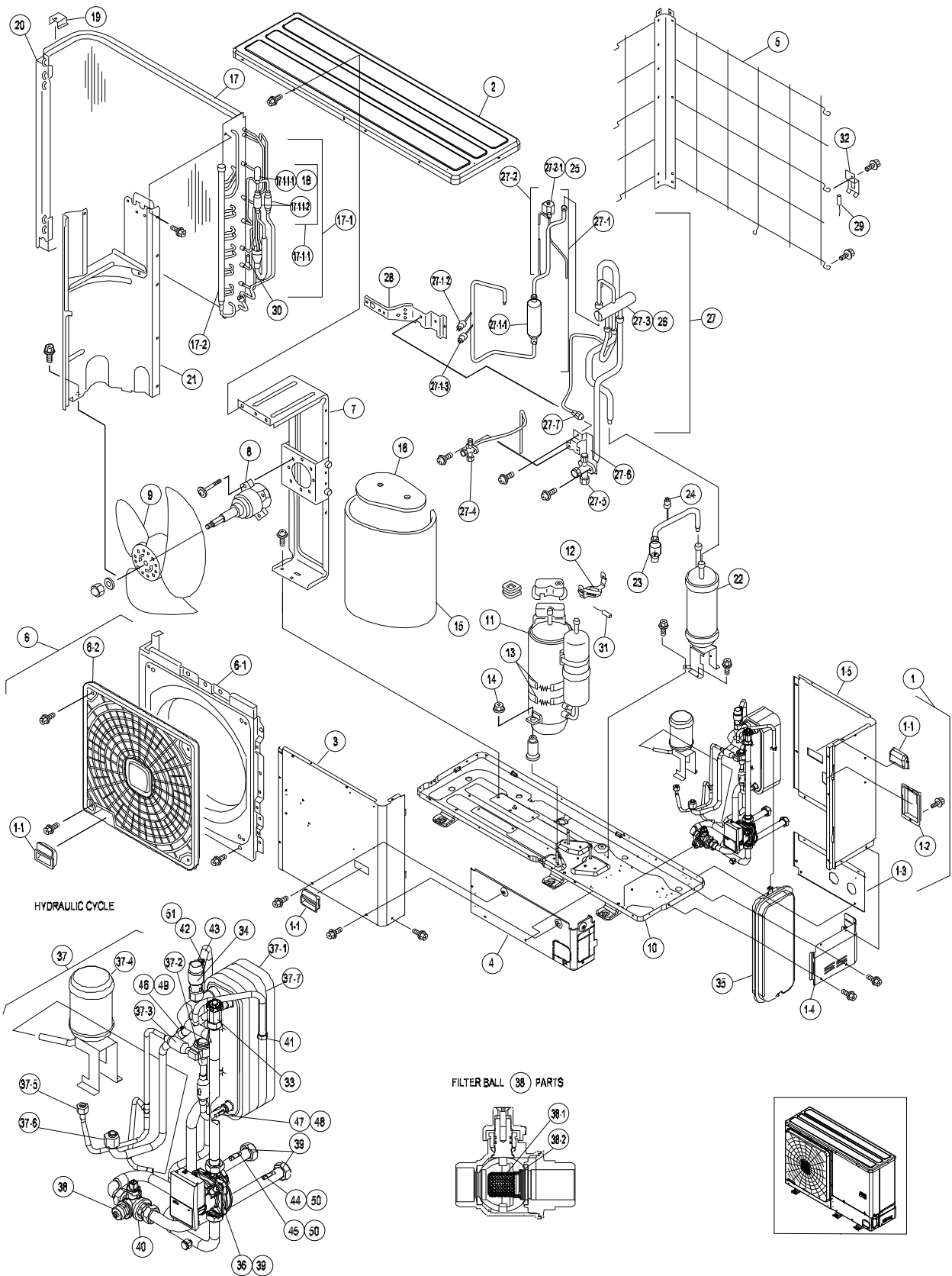



No.	DESCRIPTION	DWG No.	PART No.	MODEL NAME			REMARKS
				RASM-4NE, 3~ 230V 50HZ	RASM-5NE, 3~ 230V 50HZ	RASM-6NE, 3~ 230V 50HZ	
				PRODUCT CODE			
				7E351107	7E351108	7E351109	
1	Electrical Box	XEK01510 A	E04804	1			Assembly (2+3+Harness)
1	Electrical Box	XEK01510 B	E04805		1		Assembly (2+3+Harness)
1	Electrical Box	XEK01510 C	E04806			1	Assembly (2+3+Harness)
2	P Plate Unit	XEK12139 B	E04807	1	1	1	Assembly (2-1~2-11)
2-1	P Plate Assy	XEK37454 A	E03366	1	1	1	Assembly
2-2	PCB Additional Work	XEK39667 B	E04668	1	1	1	PCB1, PO101B Assy
2-3	Spacer	XEK30992 B	P19112	6	6	6	For PCB1
2-4	Push Spacer	XEK31888 A	E00738	2	2	2	For PCB1
2-5	Terminal Board	XEK20967 A	E00705	1	1	1	TB
2-6	Noise Filter	17B41798 A	P28595	1	1	1	NF
2-7	Spacer	XEK34315 A	E01789	6	6	6	For Noise Filter
2-8	Fuse Holder	X17C66740 A	E01015	2	2	2	
2-9	Fuse	XEK32373 D	E00810	2	2	2	20A
2-10	Reactor Unit	XEK36243 C	E03374	1	1	1	
2-11	MG SW	17B28277 B	P24721	1	1	1	Fuji Electric,FC-0/SP
3	Power Unit Assy	XEK24441 A	E03375	1	1	1	Assembly (3-1~3-2)
3-1	Power Stay Assy	XEK36266 A	E02437	1	1	1	Assembly
3-2	Inv. Fin Assy	17F04353 B	E03376	1	1	1	
4	Upper Support	XEK36287 A	E02427	1	1	1	
5	Support Ebox	XEK39553 A	E04962	1	1	1	

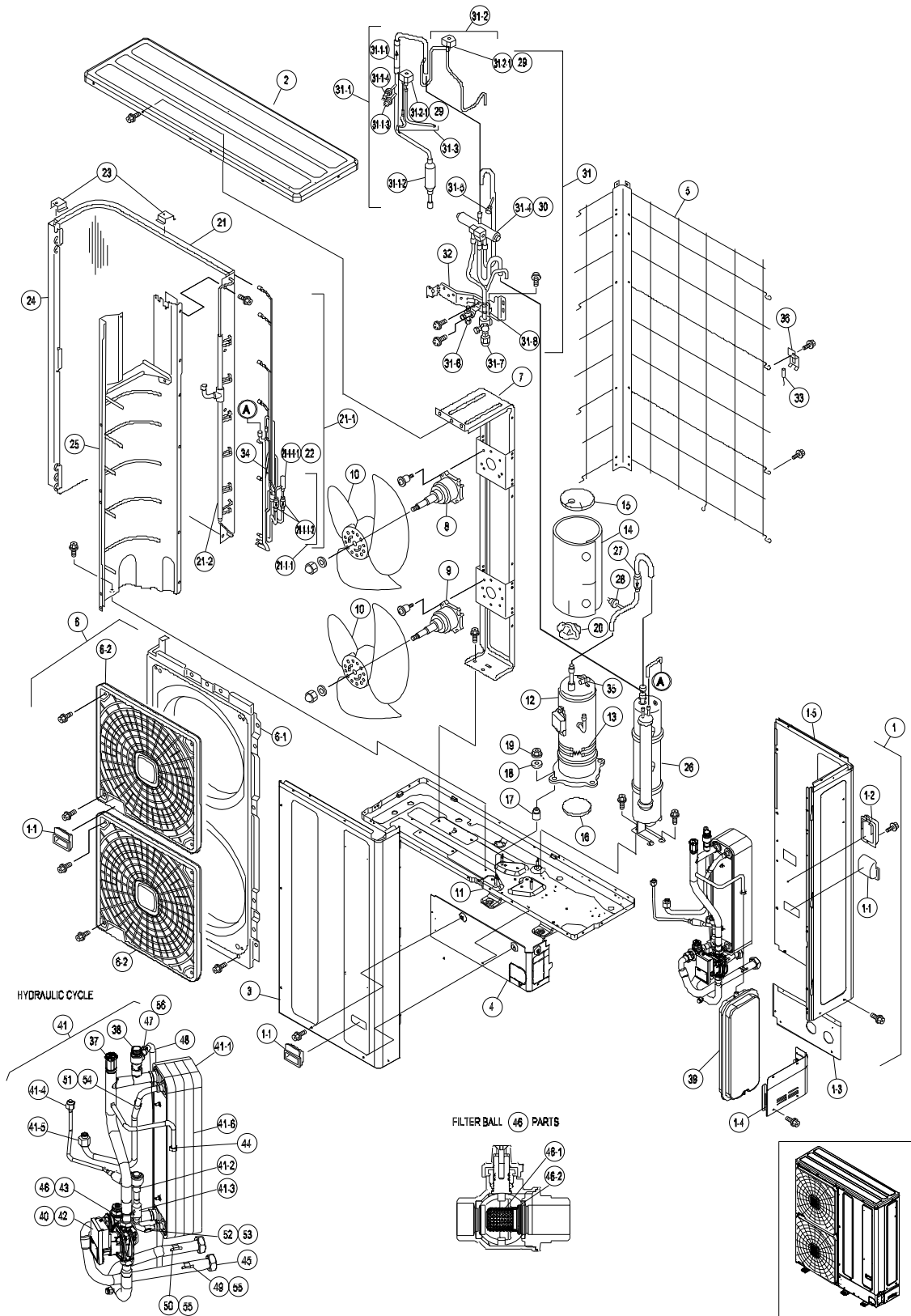

No.	DESCRIPTION	DWG No.	PART No.	MODEL NAME				REMARKS
				RASM-3VNE, 1~230V 50HZ	RASM-4VNE, 1~230V 50HZ	RASM-5VNE, 1~230V 50HZ	RASM-6VNE, 1~230V 50HZ	
				PRODUCT CODE				
1	Electrical Box	XEK01508 A	E04798	1				Assembly (2+3+Harness)
1	Electrical Box	XEK01509 A	E04799		1			Assembly (2+3+Harness)
1	Electrical Box	XEK01509 B	E04800			1		Assembly (2+3+Harness)
1	Electrical Box	XEK01509 C	E04801				1	Assembly (2+3+Harness)
2	P Plate Unit	XEK12138 D	E04802	1				Assembly (2-1~2-11)
2	P Plate Unit	XEK12138 C	E04803		1	1	1	Assembly (2-1~2-11)
2-1	P Plate Assy	XEK37454 A	E03366	1	1	1	1	Assembly
2-2	PCB Additional Work	XEK39667 A	E04667	1	1	1	1	PCB1, PO101A Assy
2-3	Spacer	XEK30992 B	P19112	6	6	6	6	For PCB1
2-4	Push Spacer	XEK31888 A	E00738	2	2	2	2	For PCB1
2-5	Terminal Board	X17C74177 A	E01818	1	1	1	1	TB
2-6	Noise Filter	17B42008 A	P28596	1	1	1	1	NF
2-7	Spacer	XEK34315 A	E01789	6	6	6	6	For Noise Filter
2-8	Fuse Holder	17C68732 A	P24729	1	1	1	1	
2-9	Fuse	XEK32372 B	P24776	1				40A
2-9	Fuse	XEK32372 C	P24728		1	1	1	50A
2-10	Reactor Unit	17G93177 A	E02419	1				
2-10	Reactor Unit	17G93177 B	E02468		1	1	1	
2-11	MG SW	17B28277 B	P24721	1	1	1	1	CMC1
3	Power Unit Assy	XEK24439 A	E03368	1				Assembly (3-1~3-2)
3	Power Unit Assy	XEK24440 A	E03369		1	1	1	Assembly (3-1~3-2)
3-1	Power Stay Assy	XEK36265 A	E02424	1	1	1	1	Assembly
3-2	Inv. Fin Assy	17C87472 J	E03370	1				
3-2	Inv. Fin Assy	17F07378 C	E03371		1	1	1	
4	Upper Support	XEK36287 A	E02427	1	1	1	1	
5	Support Ebox	XEK39553 A	E04962	1	1	1	1	

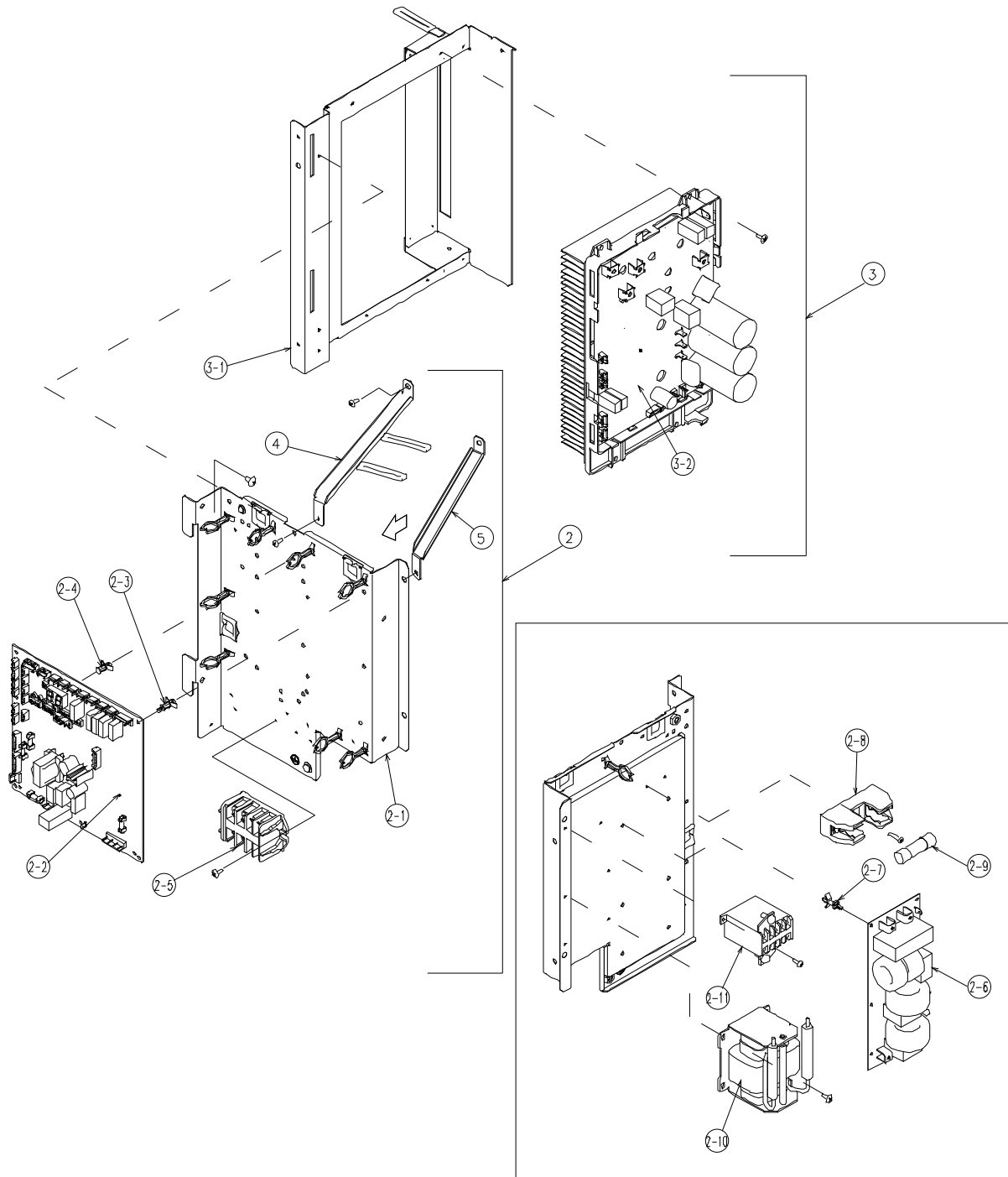

MODEL NAME	PRODUCT CODE
RASM-3VNE, 1~ 230V 50HZ	7E351005
RASM-4VNE, 1~ 230V 50HZ	7E351007
RASM-5VNE, 1~ 230V 50HZ	7E351008
RASM-6VNE, 1~ 230V 50HZ	7E351009
RASM-4NE, 3~ 230V 50HZ	7E351107
RASM-5NE, 3~ 230V 50HZ	7E351108
RASM-6NE, 3~ 230V 50HZ	7E351109

No.	DESCRIPTION	DWG No.	PART No.	Qty	Qty	Qty	Qty	Qty	Qty	Qty	REMARKS
1	PCB	XEK39262 A	E04665	1	1	1	1	1	1	1	
2	Spacer	XEK34315 A	E01789	12	12	12	12	12	12	12	
3	Terminal Board	17P00835 O	E04778	1	1	1	1	1	1	1	
4	Relay	XEK39261 A	E04779	1	1	1	1	1	1	1	
5	Fuse	XEK39253 D	E04782	1	1	1	1	1	1	1	20A
6	Fuse Holder	X17C68766 A	E02516	1	1	1	1	1	1	1	
7	Rocker Switch	XEK37911 A	E03828	1	1	1	1	1	1	1	
8	Harness lifter	17G37442 A	E04783	3	3	3	3	3	3	3	
9	Ending Saddle	17G05481 A	E04784	2	2	2	2	2	2	2	
10	Electrical Box	XEK01512 A	E04789	1	1	1	1	1	1	1	Assembly (Plate + Components + Harness)
11	E-Box	XEK12712 A	E04790	1	1	1	1	1	1	1	Only plate (without components)

