

SCHALTPLAN RCD-(1.0-3.0)FSN2

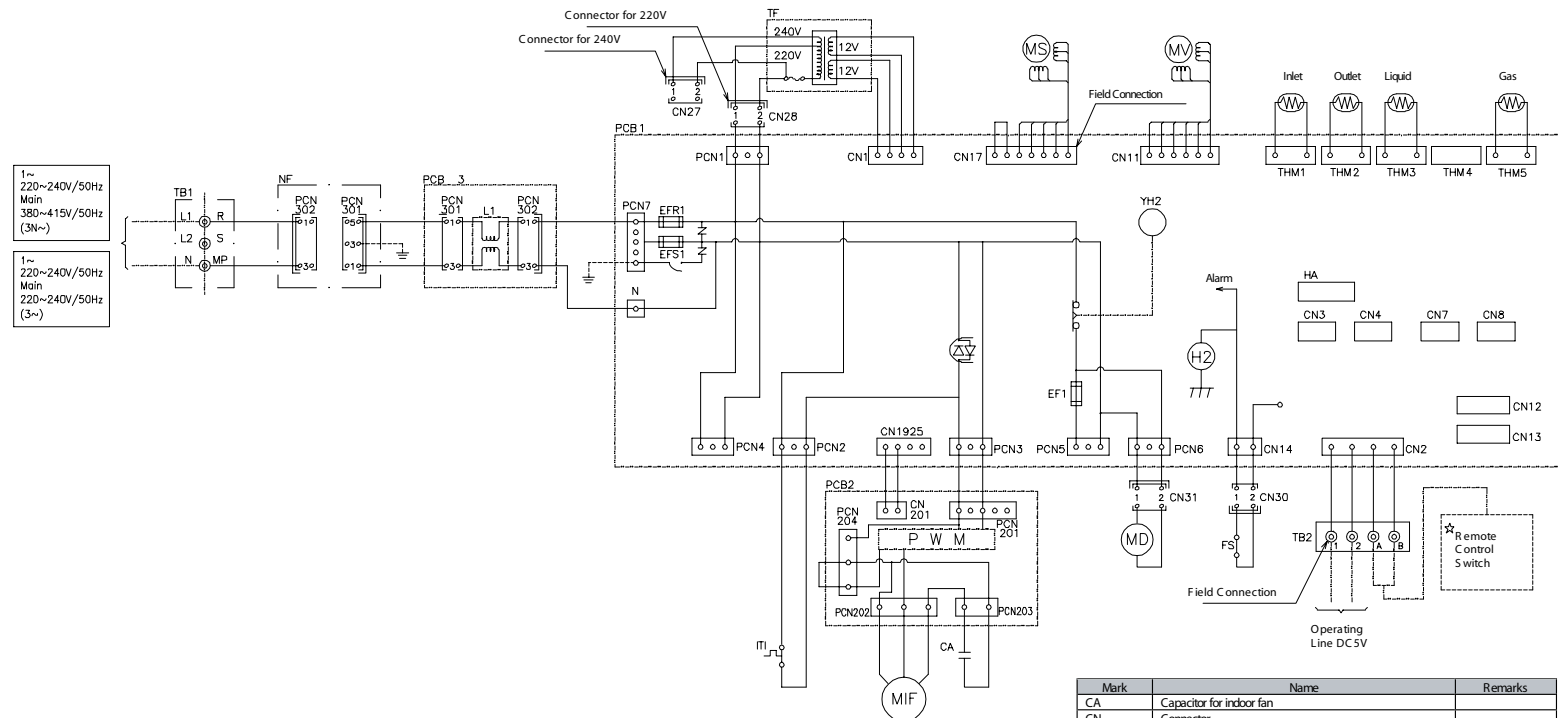

Printed Circuit Board

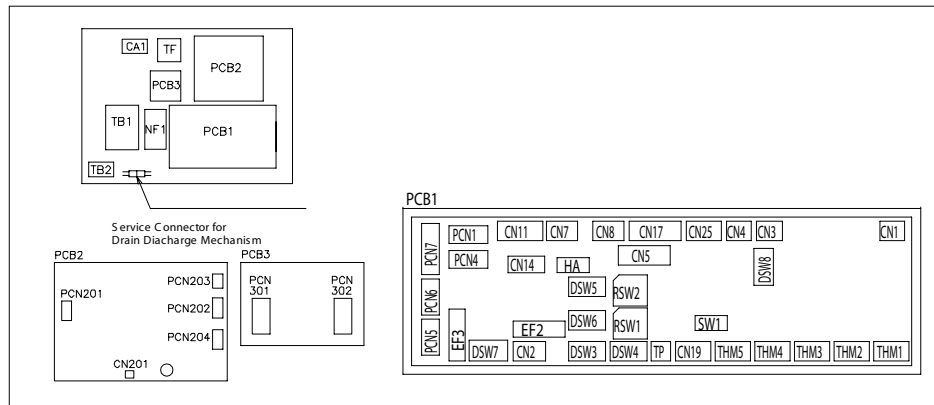

Mark	Name	Remarks
CA	Capacitor for indoor fan	
CN	Connector	
DSW 3	Unit Capacity Code	On PCB1
DSW5	Refrigerant Cycle No.	On PCB1
DSW6	Model code	On PCB1
DSW7	Fuse recover/ Remote Controller Selector	On PCB1
EF1,1	Fuse	On PCB2
EF1,2	Fuse	On PCB1
FS	Float Switch	
IT1	Internal thermostat for indoor fan motor	
MD	Motor for Drain Discharge Mechanism	
MIF	Motor for Indoor Fan	
MS	Motor for Automatic Swing Louver	
MV	Micro-Computer Control Expansion Valve	
NF	Noise Filter	
PCB1,2,3	Printed Circuit Board	
PCN 1-203	Connector on PCB	On PCB
RSW 1, RSW 2	Indoor Unit No. Settings	On PCB1
TB1,2	Terminal Board	
TF	Transformer	
THM1	Inlet Air Thermistor	
THM2	Outlet Air Thermistor	
THM3	Liquid Pipe Thermistor	
THM4	Gas Pipe Thermistor	
THM5	Gas Pipe Thermistor	
YH2	Relay	On PCB1
⊙	Terminals	
— —	Close-end Connector	
☆	Optional Parts	
----	Field Wiring	
-----	Earth Wiring	
=====	Factory Wiring	
*	Field Connection	