

# SCHALTPLAN RAS-(8-10)HN(P/C)E

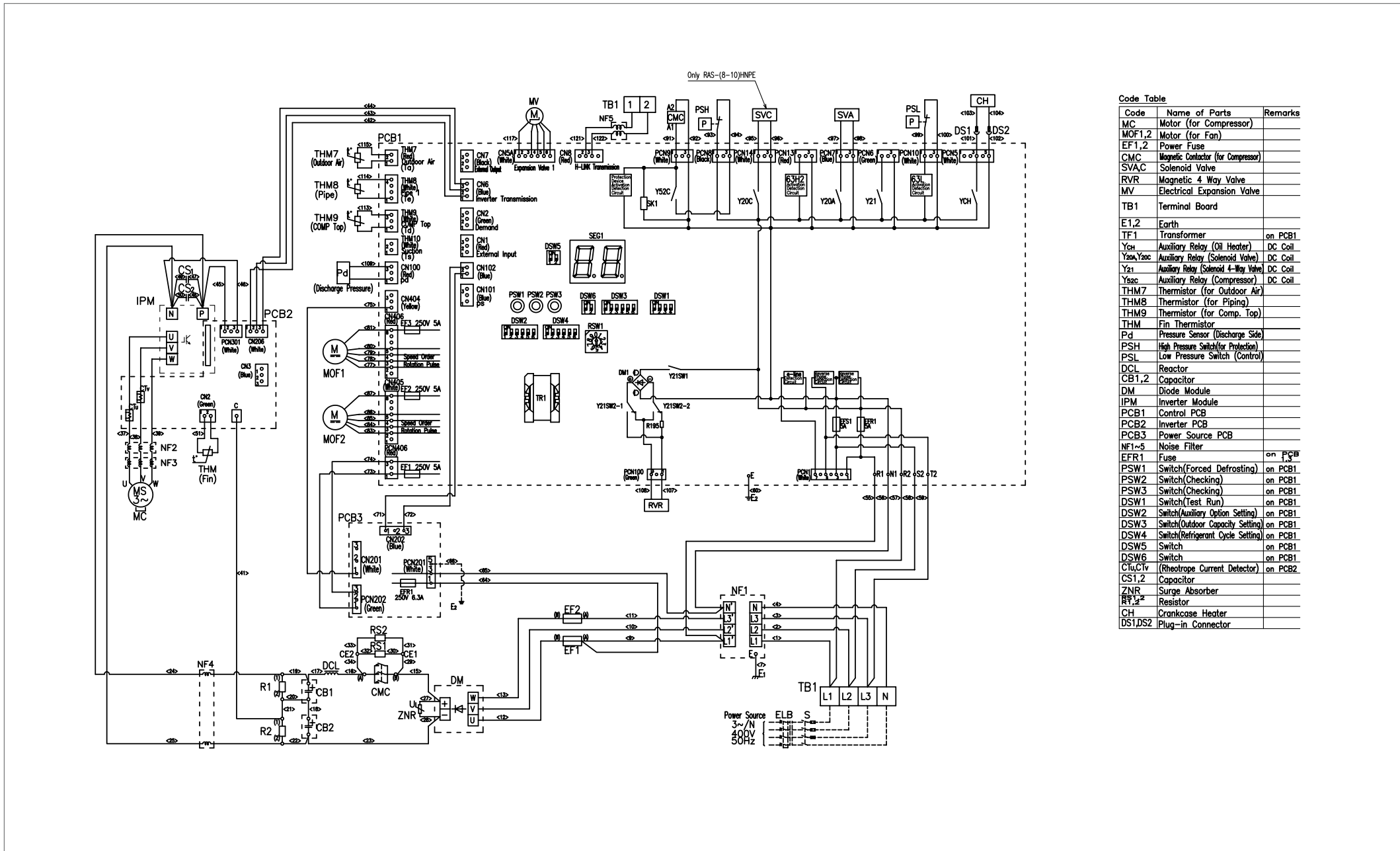

Code	Name of Parts	Remarks
MC	Motor (for Compressor)	
MOF1,2	Motor (for Fan)	
EF1,2	Power Fuse	
CMC	Magnetic Contactor (for Compressor)	
SVAC	Solenoid Valve	
RVR	Magnetic 4 Way Valve	
MV	Electrical Expansion Valve	
TB1	Terminal Board	
E1,2	Earth	
TF1	Transformer	on PCB1
Ych	Auxiliary Relay (Oil Heater)	DC Coil
Y20a, Y20c	Auxiliary Relay (Solenoid Valve)	DC Coil
Y21	Auxiliary Relay (Solenoid 4-Way Valve)	DC Coil
Y22c	Auxiliary Relay (Compressor)	DC Coil
THM7	Thermistor (for Outdoor Air)	
THM8	Thermistor (for Piping)	
THM9	Thermistor (for Comp. Top)	
THM	Fin Thermistor	
Pd	Pressure Sensor (Discharge Side)	
PSH	High Pressure Switch (for Protection)	
PSL	Low Pressure Switch (Control)	
DCL	Reactor	
CB1,2	Capacitor	
DM	Diode Module	
IPM	Inverter Module	
PCB1	Control PCB	
PCB2	Inverter PCB	
PCB3	Power Source PCB	
NF1~5	Noise Filter	
EFR1	Fuse	on PCB3
PSW1	Switch (Forced Defrosting)	on PCB1
PSW2	Switch (Checking)	on PCB1
PSW3	Switch (Checking)	on PCB1
DSW1	Switch (Test Run)	on PCB1
DSW2	Switch (Auxiliary Option Setting)	on PCB1
DSW3	Switch (Outdoor Capacity Setting)	on PCB1
DSW4	Switch (Refrigerant Cycle Setting)	on PCB1
DSW5	Switch	on PCB1
DSW6	Switch	on PCB1
C1u, C1v	(Rheotrope Current Detector)	on PCB2
CS1,2	Capacitor	
ZNR	Surge Absorber	
RT, R	Resistor	
CH	Crankcase Heater	
DS1, DS2	Plug-in Connector	